

Viewtech Heavy Duty Side Mount Camera



Features

- IP69K water rating (can be pressure washed)
- 500TVL Resolution
- rubber mounting plate
- Sony Colour CCD
- IR illumination
- cast aluminium housing (powder coated)
- 140° Wide angle view
- built in audio
- adjustable 3 axis camera gimble
- watertight 4pin connection (rca adaptor available)

Specifications

Part VT406

Sensor	1/3" CCD
Resolution	500TVL
Lens	2.1mm Fixed
Min illumination	0.0Lux with IR on
Water/Dust Rating	IP69K
IR	5 IR LEDs
Power	12V DC
Audio	Yes
Dimensions	56 (W) x 41 (H) x 68 (D)

IP69K Certified

IP69K Test Aparatus, 15L/min at 10000KPa around 360°



Applications

- forward facing roof mount on bus / truck
- blindspot camera for trucks and trailers
- door monitoring camera for city bus and coach
- reversing camera

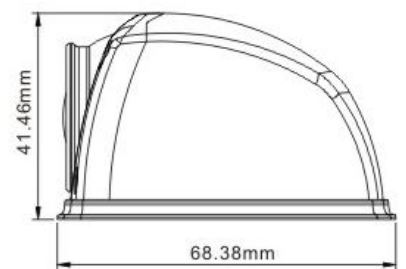
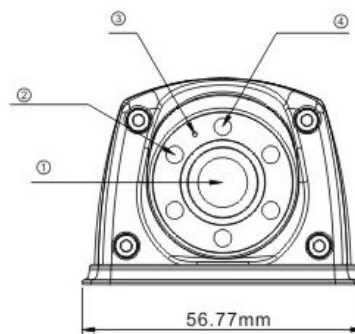

www.viewtech.co.nz 0800 888 324
sales@viewtech.co.nz

1	Lens
2	IR Lights
3	Microphone hole
4	Light sensitive resistor